

PACEPACKER SERVICES

Automation with imagination....



T20-MX SACK PLACER

THE UK'S MOST WIDELY USED, COST EFFECTIVE AND
VERSATILE SACK PLACER.

PACEPACKER

Operation

Robust construction with large bore vacuum system gives smooth, fast and reliable operation on a wide variety of sack materials. A sack is lifted from the pile and indexed forward to a precise point, ready for opening. This opening point is controlled by an adjustable sensor for accurate positioning. Two sets of suction cups then open the bag allowing the swing arm blades to enter and grip the bag. The swing arms then rotate up to the sack clamp.

Options

T20-MX	Single-Pile Sack Tray
T21-MX	Multi-Pile Sack Magazine
T22-MX	As T21-MX with Sack Tail Separator for Plastic and WPP Sacks
T23-MX	Empty Sack Printing or Label Application

Control System

The T-Series control system utilises the latest PLC technology. It incorporates a very user friendly operator interface (HMI Screen) which has a clear display and powerful new features. These include a recipe system providing up to seven different programmes which can be pre-set for various bag types and sizes. Other features include a Modem option for remote diagnostics and editing, visual fault display and self diagnostic functions.

Packing Speeds

Packing speeds depend on many factors such as weigher speed, filling time, conveyor speed etc. Typical speeds for the T-Series is 720 sacks per hour or 12 bags per minute. However speeds up to 900 bags per hour or 15 bags per minute are possible.

Weigher Requirements

Works with almost any fully automatic net or gross weigher or volumetric filler.

Sack Specification

Most commercial quality paper, plastic, WPP and laminated sacks are acceptable, providing they are in good condition and stack neatly. Multiwall paper sacks must be pasted between layers. Plastic sacks must be between 100 and 200 Micron. (400-800 Gauge), must be dry and free from static. WPP sacks must have a tight weave to allow the vacuum system to work. They must be flat and not cut with a hot knife. Unsuitable sacks such as Hessian and Nets can be placed manually via a supplied foot pedal.

Electrical Requirements

Standard: 415V, 50/60 Hertz 3 Phase, 10 Amp Supply. Alternatives can be accommodated.

Air Requirements

Cool, clean, dry air at 6 bar (90 PSI) at 27Litres (1 CuFt) per cycle. I.e. 12 cfm at 12 sacks per minute 20mm (3/4") supply pipe minimum.

Shipping Specification

Case Size (mm); 1,900 x 1,000 x 2,200 high.
Gross Weight; 320 Kg.



Typical Dimensions Shown, Equipment Manufactured To Suit Each Installation.

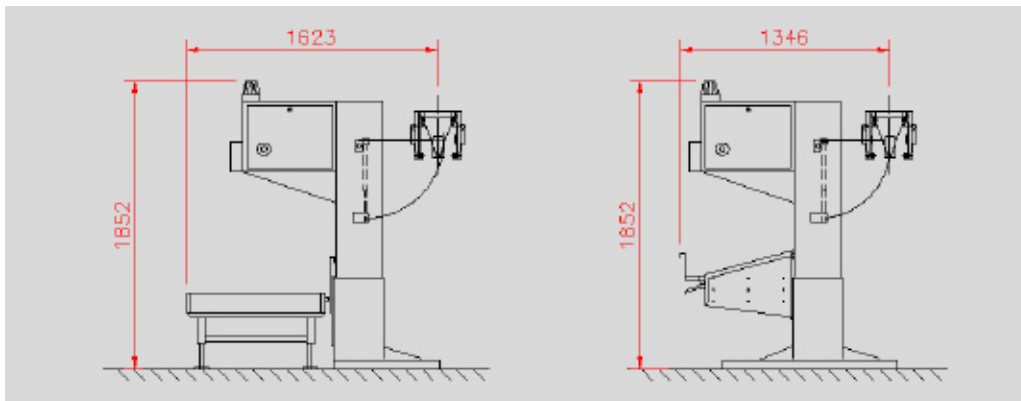

Pacepacker Services Limited

Unit 16 Bluegate Hall,
Great Bardfield,
Essex, CM7 4PZ.
England.

Tel: +44 (0) 1371 811544
Fax: +44 (0) 1371 811621

www.pacepackerservices.com