

CARETAKER MOBILE GRADER

QUALITY HANDLING EQUIPMENT



2400 Caretaker Classic



2100 – 1800 Caretaker Classic

Our range of grading equipment is comprehensive & takes care of your valuable crop

The Caretaker is Tong Peal's market leading mobile grader and is available in Classic and Compact models depending on your throughput needs. Designed to your specific requirements, the largest models of the Caretaker are capable of cleaning & grading up to 50 tonnes of crop per hour and are ideal for handling your crop processing needs from start to finish.

A typical Caretaker mobile grading line comprises of an in-feed hopper, presentation conveyor, your choice of a range of crop cleaners including the Evolution cleaner, Easy-Grade screen sizing module and inspection table and can be custom designed to meet your exact cleaning and grading needs.

CARETAKER SPECIFICATION DATA

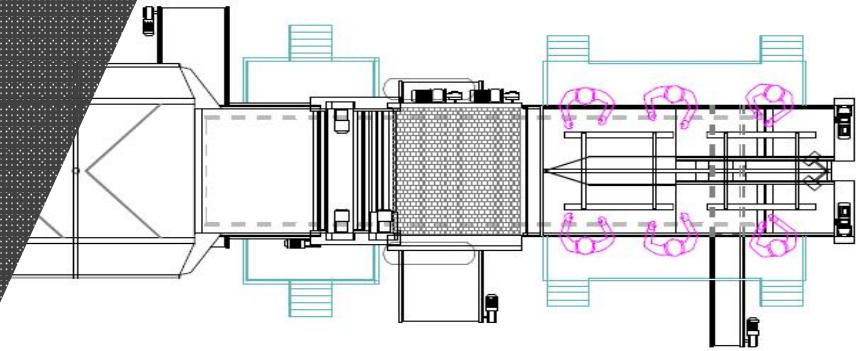

Caretaker In-feed Hoppers:

Manufactured in a range of widths to suit your requirements.

- Standard rear entry size of 3.1m
- Thick reinforced rubber belt with vulcanised V cleats
- Belt supported by heavy duty 4" pitch chain
- 12.5 x 18 wheels and removable draw bar
- Drive system to provide extra strength and reliability
- Inverter variable speed
- Hopper flow sensor for automatic crop detection



Dry Cleaner Separator Options:

For a superior cleaning process we advise a presentation conveyor is fitted before the cleaner.

- 4, 6, 8 or 10 row EasyClean, available with HMI control
- 4 or 6 rows of fixed or adjustable coils
- Galaxy cleaner with Verticam
- Inverter variable speed
- Access stands and maintenance platforms optional
- Remote panel for local control of separation



Easy Grade Screen Module:

Tong Peal's easy grade screen module is designed to handle your crop as gently and efficiently as possible.

- Dual pintle roller drive
- Variable speed screen motor
- Variable speed agitator motor
- Long tuber handling device
- Rubber covered transfer roller for gentler handling
- Steel, plastic and rubber screens all available



Inspection Table:

Built to your exact specification, Tong Peal specialise in manufacturing to meet your specific requirements.

- Flat belt with centre turning roller
- Option of rollers in lieu of belts
- Half roller, half belt available
- Centre reject chutes
- Full width underbelt to take all waste to a central point
- Variable speed by remote panel on inspection table
- Fluorescent light and diffuser

T/ +44 (0)1790 752771
F/ +44 (0)1790 753611
E/ sales@tongpeal.com

Tong Engineering Ltd, Ashby Road, Spilsby, Lincolnshire, PE23 5DW

WWW.TONGPEAL.COM