

BAG & BOX TIPPING

QUALITY HANDLING EQUIPMENT



Twin Big Bag & Box Tippers with forward conveyors



150° Box Tipper with forward conveyor



Heavy duty 160° Bag & Box Tipper

Our range of bag & box tippers is comprehensive & offers gentle, efficient handling of crop

Designed to meet your specific requirements and manufactured with the latest technology and safety features, Tong Peal bag and box tippers offer robust and reliable tipping, with gentle handling in mind.

Tong Peal's Heavy Duty 160° Control Flow Box Tipper is one of the widest tipping box tippers on the market. The tipper features the latest ram tipping mechanism design with enhanced strength, resulting in less strain on linkages for an even more robust and low maintenance machine. The fully automated tipper handles boxes up to 2 tonnes, or can be custom built to effectively tip and empty 1.25 ton bags. The latest addition to the Tong Peal tipping range is the new side eject box tipper featuring a new robust paddle side eject mechanism. The tipper has been specifically designed to keep a continuous flow of crop onto grading and washing lines, with minimal forklift movement and greater time efficiency.

SIDE EJECT 160° BOX TIPPER SPECIFICATION DATA

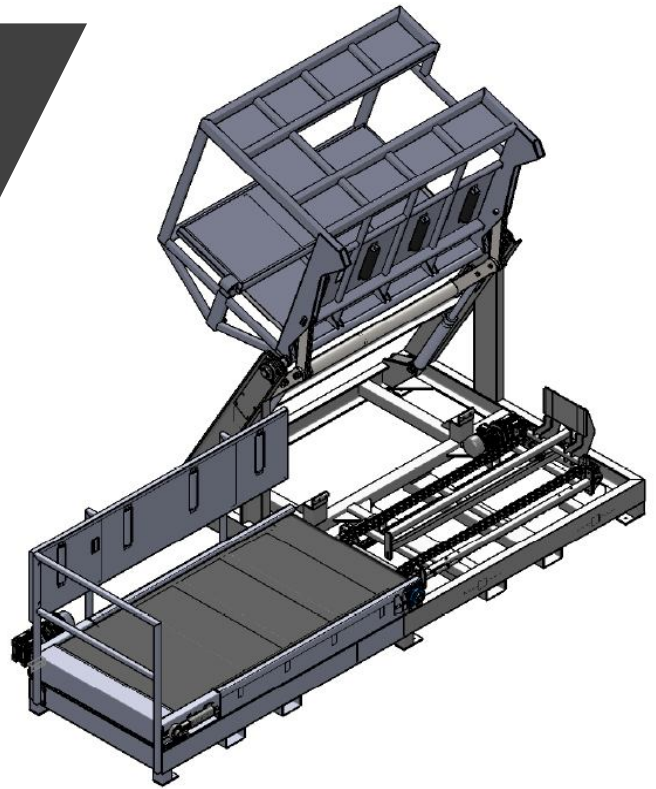

Side Eject 160° Box Tipper:

Manufactured with a new side eject mechanism based on a heavy duty chain and paddle construction the latest 160 degree ram tipping mechanism for robust, efficient & continuous tipping

Optional Extras include:

- Cross Conveyor
- Forward Conveyor (as pictured above)
- Auto-speed change
- Hydraulic clamp lid
- Hydraulic flow door
- Single box tipper with twin hydraulic rams
- Heavy duty chain and paddle side eject mechanism and conveyor
- 160° heavy duty tip mechanism
- Automatic via micro-processor and sensors
- Manual override in control panel
- Box movement siren
- Box empty beacon
- One set cradle inserts
- Side safety guards



T/ +44 (0)1790 752771
F/ +44 (0)1790 753611
E/ sales@tongpeal.com

Tong Engineering Ltd, Ashby Road, Spilsby, Lincolnshire, PE23 5DW

WWW.TONGPEAL.COM