

BIG BAG BINS

QUALITY HANDLING EQUIPMENT



Big Bag Filling Bin

Tong Peal Big Bag Bins offer an economical and versatile solution for filling bags and sacks

With a holding capacity of up to 1200kg and a simple manual handle for the 'Bomb Door' opening, once the bag is hooked onto the arms and the door is opened, the bin is lifted by its fork-lift tubes and the bag fills. Tong Peal's Big Bag Bins are suitable for use with box fillers as an alternative to conventional boxes when bag filling is required.

- Filled by box filler
- Holding capacity 1200kg
- Fork Lift tubes & bag holders
- 'Bomb Door' opening with manual handle

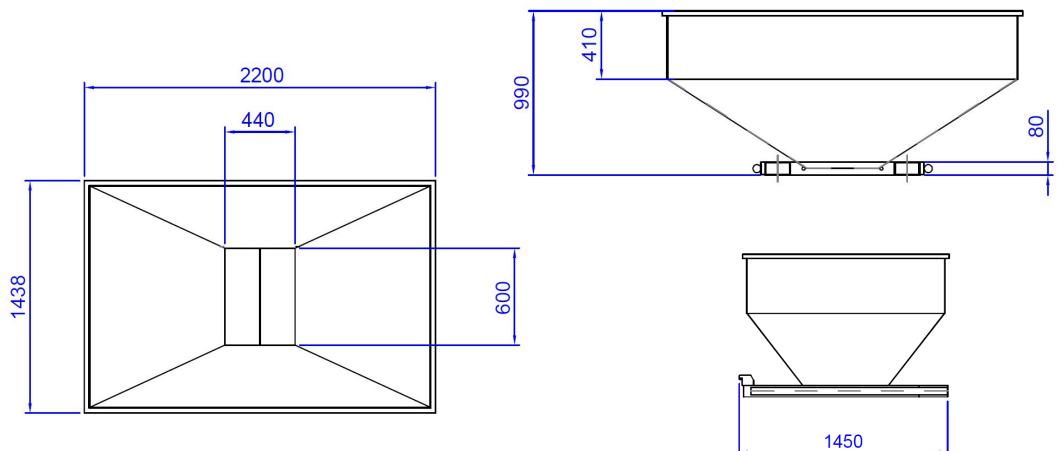

SELF TIP SKIPS

QUALITY HANDLING EQUIPMENT



Tong Peal Self Tip Skips are the ideal solution for collecting general waste & keeping your premises tidy

Suitable for use with most forklifts, self tip skips make light work of collecting waste from packhouses, farm yards, grading lines, workshops and building sites.

- Single lever action
- Automatic tip & return
- 3-entry forklift access points
- 1 and 2 ton models
- Bespoke sizes made to order

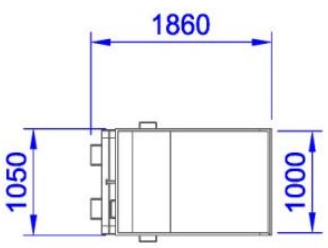
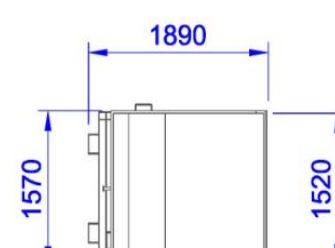
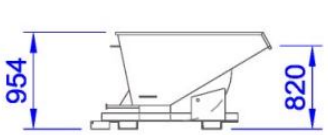
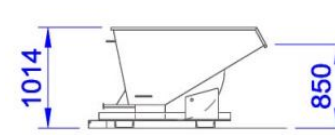
1 TON MODEL	2 TON MODEL
	
	
<p>0.75 cubic metre capacity 500 litre liquid capacity Weight: 250kg</p>	<p>1.35 cubic metre capacity 830 litre liquid capacity Weight: 300kg</p>